

REVISIONS					
P	LTR	DESCRIPTION	DATE	DWN	APVD
	T2	REVISED PER ECR-21-113405	31MAY2022	SS	DH

- 1 CONTINUOUS STRIP ON REELS
- 2 MATING TAB THK IS .033-.030.
- 3 WIRE SIZE IS #18-#14 AWG
- 4 INSULATION RANGE IS .120-.170 DIA.
- 5 THE GAP ON THE ROLLS TO BE IN CONTACT WITH THE TAB FOR THE LENGTH OF THE ROLL BEHIND THE LEAD-IN.

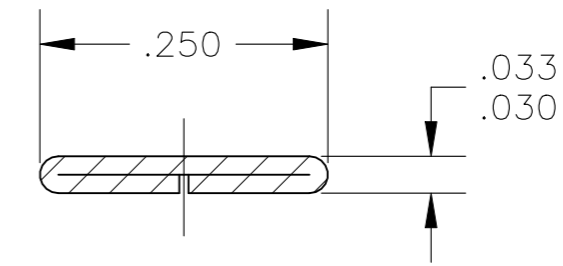

SECTION B-B

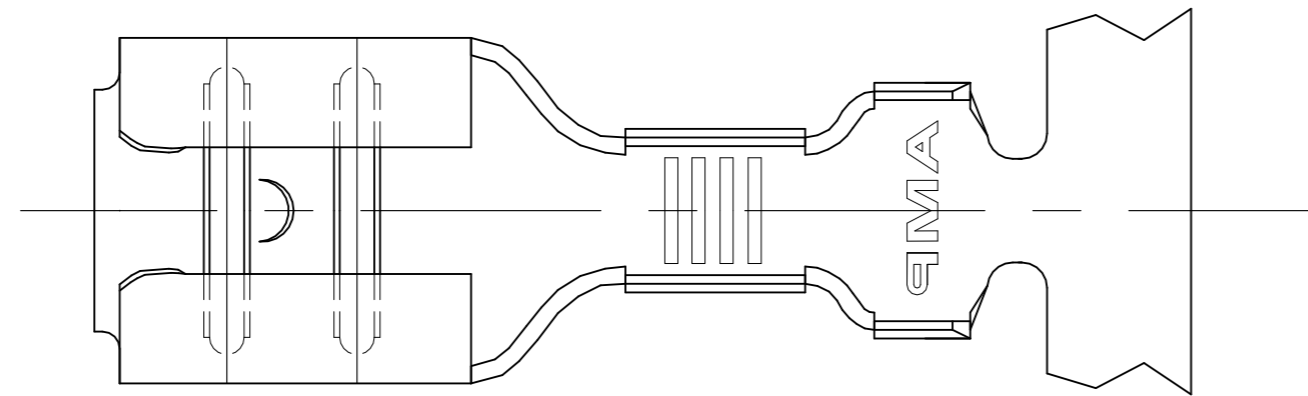
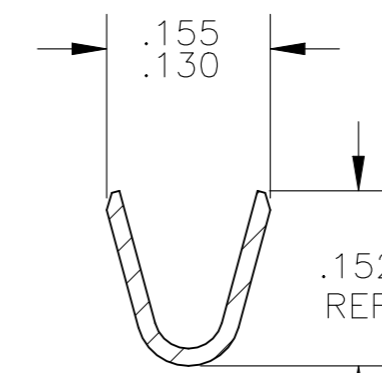
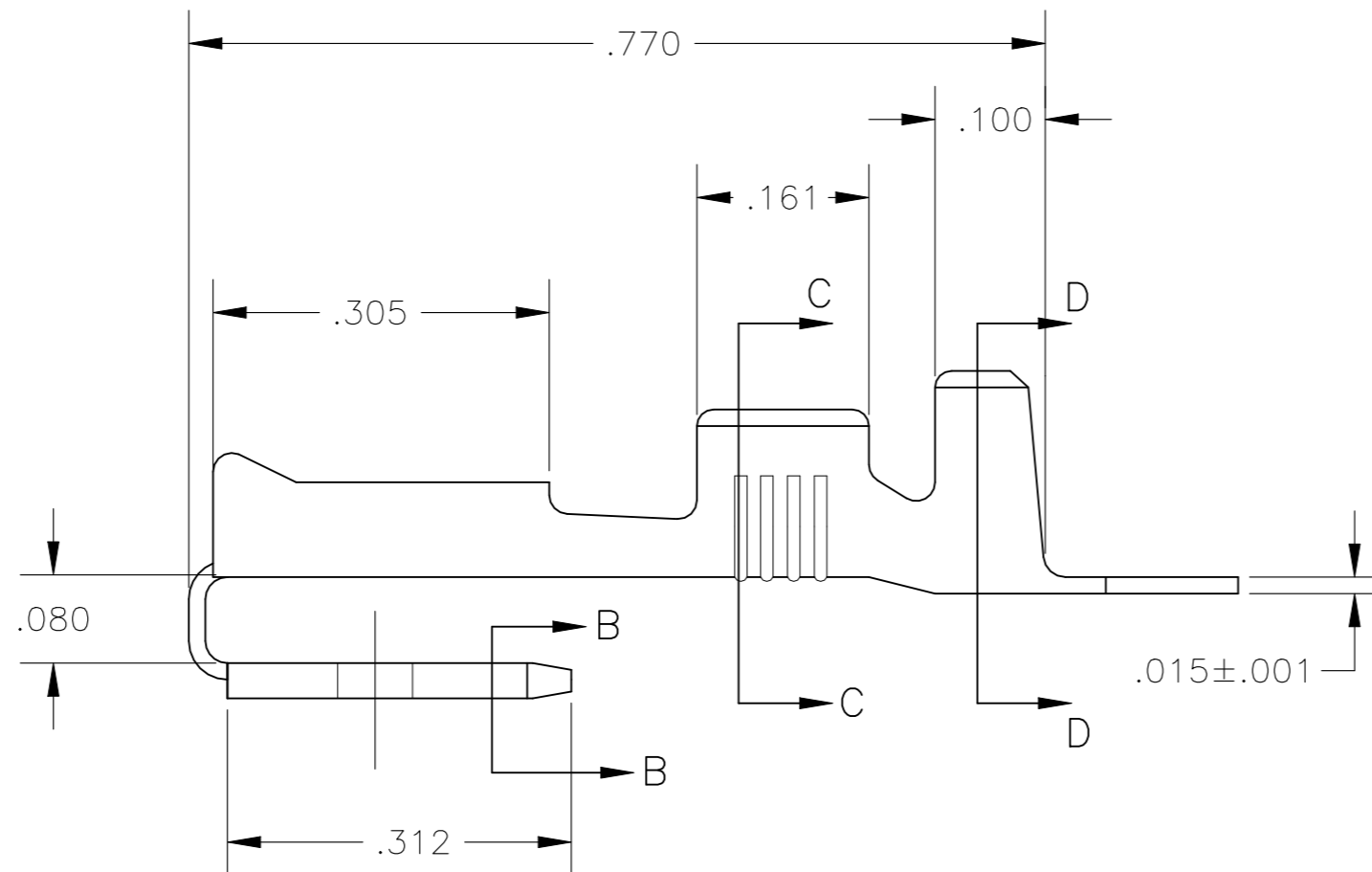

SECTION C-C

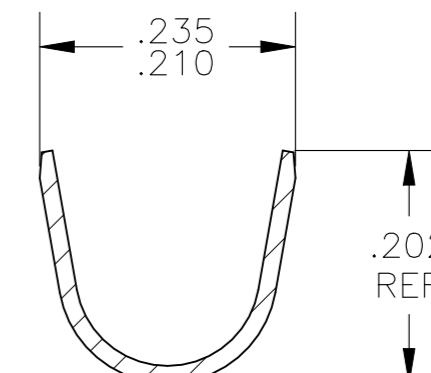

SECTION D-D

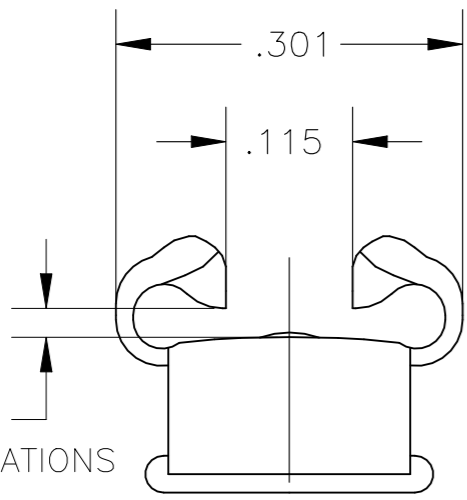

GAP AS REQUIRED TO MEET FORCE SPECIFICATIONS AND .028 MAX

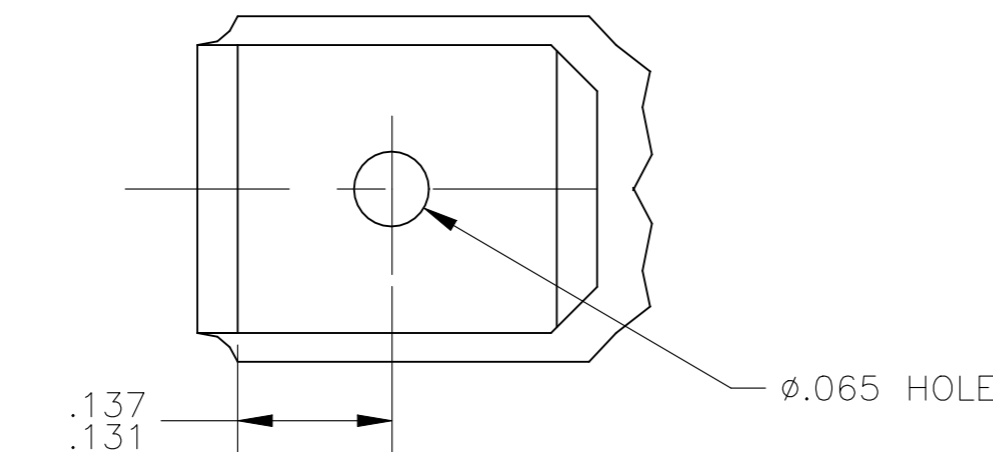

— OBSOLETE	SILVER PLATE	61944-4-
— OBSOLETE	PRE TIN PLATE	61944-3-
	TIN	61944-2
	—	61944-1
	FINISH	PART NO.

THIS DRAWING IS A CONTROLLED DOCUMENT.		DWN	JR RUTH	26JUL2002		RECEPTACLE, FASTON, PIGGYBACK, 250 SERIES																					
DIMENSIONS: INCHES		CHK	P DESANTIS	26JUL02		NAME																					
TOLERANCES UNLESS OTHERWISE SPECIFIED:		APVD	P DESANTIS	26JUL02		PRODUCT SPEC																					
<table border="0"> <tr><td>0 PLC</td><td>±</td><td>-</td></tr> <tr><td>1 PLC</td><td>±</td><td>-</td></tr> <tr><td>2 PLC</td><td>±</td><td>-</td></tr> <tr><td>3 PLC</td><td>±</td><td>.015</td></tr> <tr><td>4 PLC</td><td>±</td><td>-</td></tr> <tr><td>ANGLES</td><td>±</td><td>-</td></tr> </table>		0 PLC	±	-		1 PLC	±	-	2 PLC	±	-	3 PLC	±	.015	4 PLC	±	-	ANGLES	±	-	APPLICATION SPEC		114-2082		SIZE	CAGE CODE	DRAWING NO
0 PLC	±	-																									
1 PLC	±	-																									
2 PLC	±	-																									
3 PLC	±	.015																									
4 PLC	±	-																									
ANGLES	±	-																									
MATERIAL	BRASS	FINISH	SEE TABLE	WEIGHT	0.000000	A2	00779	C=61944	—																		
CUSTOMER DRAWING						SCALE	6:1	SHEET	1 OF 1	REV	T2																